

Wireless Engineering Group : GuruPlug Manufacturing Process

This page last changed on Mar 31, 2010 by [mjain](#).

- [Objective](#)
- [Prerequisites](#)
- [Setup](#)
- [Steps](#)
 - [Getting MTP suite](#)
 - [Preparation Fedora-11 machine](#)
 - [Connections:](#)
 - [Test suite format](#)
 - [Entire procedure for Guruplug image burning and testing](#)
 - [Verification and Reports](#)
 - [For subsequent boards](#)
 - [Wireless association from Linux machine](#)

Objective

To program Wireless Sheevaplug with the pre-decided out of the box settings.

Prerequisites

Software Requirements:

GuruPlug_mtp.tar.bz2 tar ball can be downloaded from [here](#). The tarball contains following things:

- uboot.guruplug.bin, kernel(uImage-guruplug), rootfs.ubi.img
- testenv_install_2.sh
- openocd binary, openocd configuration - sheevaplug.cfg: To flash uboot into internal NAND flash
- ubootTest.tcl which is under uboot_test_suite directory: Uboot test suite for dram, nand & network tests
- diag_plug2-w.pl: For burning kernel & rootfilesystem to internal nand flash
- TFPT, libusb, libftdi rpms, ftdi modules & config files
- perl modules & other dependencies

Hardware Requirements:

- Fedora-11 laptop with wireless (wifi) capability
- GuruPlug board(s) with FTDI connector for console and JTAG
- 2 USB sticks that are FAT16/FAT32 formatted
- 1 microSD that are FAT16/FAT32 formatted flash device
- Ethernet cable/hub etc.

Setup

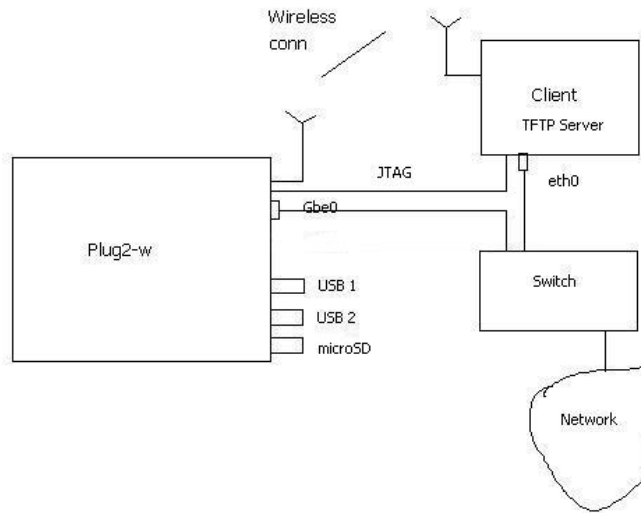

Steps

Getting MTP suite

Please download manufacturing utilities tarball and README from

http://10.82.108.51/mjain/GTI/GuruPlug_mtp.tar.bz2

http://10.82.108.51/mjain/GTI/Guruplug_README.txt

Preparation Fedora-11 machine

- Copy GuruPlug_mtp.tar.bz2 to /home directory.
- Run

```
tar -xjvf GuruPlug_mtp.tar.bz2
```

- Go to testenv directory i.e cd /home/testenv/
- Run

```
./testenv_install_2.sh.
```

- Please reboot the machine

This script will prepare fedora-11 machine for,

- NFS server & directory containing nfs root filesystem.
- TFTP server with tftp configuration & kernel image.
- Perl modules like expect, IO:tty.
- tcl 8.5
- Auto loading modules like usbserial, ftdi_sio etc.

Above is one time process for preparing fedora-11 machine. Once this is done there is no need to re run this command again for further manufacturing flow.

Connections:

- Connect the miniUSB cable from the Guruplug to the host machine's USB port

- Connect the power cable to the Guruplug and power it on

Test suite format

```
$ls /home/testenv/
configs      ks.cfg      rootfs-plug2.tar.gz  sheevaplug      uboot_test_suite
ftdi_sio.ko  perl_modules  rpms             testenv_install_2.sh  usbserial.ko

$ls /home/testenv/sheevaplug
diag_plug2-w.pl  loadftdi.sh  openocd.binaries

$ls /home/testenv/uboot_test_suite
config.txt  lib  README.txt  uboot_test_03.txt  uboot_test_04.txt  uboot_test_06.txt  ubootTest.tcl
```

Entire procedure for Guruplug image burning and testing



Run following commands on host machine's terminal

- Connect Guruplug with JTAG connector, power it on.
- Change into the directory /home/sheevaplug/openocd.binaries/bin/, which is generated by the testenv_install_2.sh script and use the openocd tool to burn the uboot. Run following commands,

```
cd /home/sheevaplug/openocd.binaries/bin
./openocd -f target/board/sheevaplug.cfg -c init -c sheevaplug_reflash_uboot -c exit
```

After this is done , power off the plug.

- Connect the plug and your host to a switch, and set your host's ethernet ip address:10.4.50.5,netmask:255.255.255.0.
- Enter the directory /home/uboot_test_suite & run following command

```
./ubootTest.tcl
```

Power on the plug. This will run uboot diagnostics & will display each test status as Pass or Fail. After test suite is done executing, power off plug.

- Change into the directory /home/sheevaplug & run following command,

```
./diag_plug2-w.pl
```

Power on the plug.This will ask following parameters,

Enter mac address 1:

After mac address is entered, the script will write kernel & root filesystem to internal NAND flash. Then it will boot from debian rootfilesystem from NAND flash and will run Linux tests. After that the script it will ask to associate wireless client & enter the ip address of the client. Please follow the steps in the section "Wireless association from Linux machine" below when prompted for this. The script then will perform wireless tftp tests.

- Every step will display test status as PASS or FAIL. If any test fails then it will not perform any further tests.

Verification and Reports

The above two scripts generate following results files,

```
./ubootTest.tcl -> uboot_test_results.txt
                  command_log.txt

./diag_plug2-w.pl -> <mac-addr>.log (where mac-addr is mac address you entered)
```

These files describe in detail all the commands and their results that are run during tests.

For subsequent boards

All the steps starting from openocd step mentioned above need to be repeated for each subsequent board.

Wireless association from Linux machine

Fedora-11 machine has NetworkManager tool. Select "GuruPlug-<last two bytes of MAC address>" SSID which is the default SSID for Guruplug & associate with it. It is unsecured network so there is no need to enter any wireless security password. After successful association, the Guruplug gets an ip address in the range 192.168.1.100 - 192.168.1.200.

When prompted by diag_plug2-w.pl script to enter ip address, please enter this ip address.



If there is no NetworkManger icon on your fedora-11 Linux machine, then start it using command `$/etc/init.d/NetworkManager start` issued at the terminal (logged in as root)